

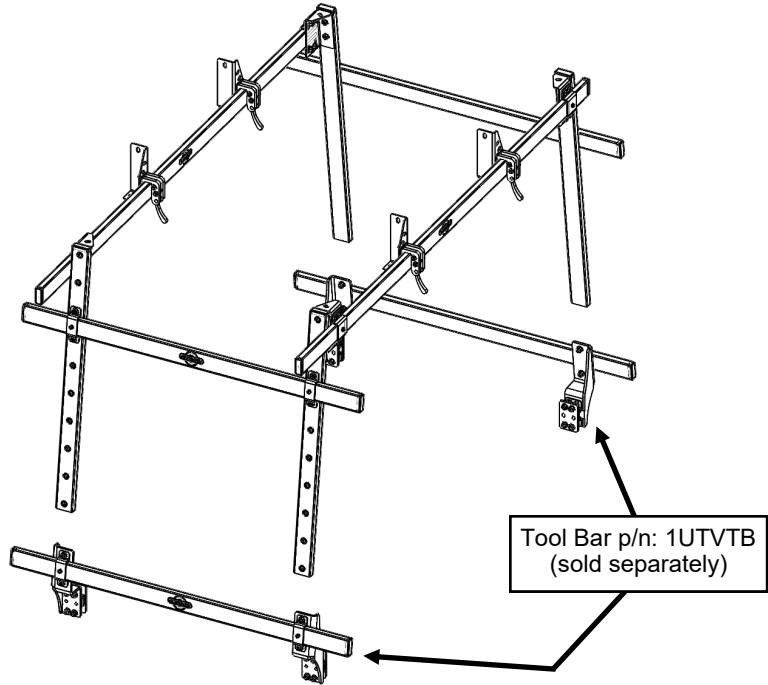

**ARTILLIAN UTV BED MOUNTED TOOL RACK  
P/N: 1UTVRK**



The **Artillian UTV Bed Mounted Tool Rack** is an innovative system to convert your UTV Tool Bar system into a full bed rack for carrying ladders, wood, and any of the *Artillian ROPS Mounted Tool Bar Accessories*. The Tool Rack attaches to two Tool Bar kits (p/n: 1UTVTB, sold separately) which attach to most vehicle beds in minutes (some drilling may be required). The base Tool Bar kit is 42" wide with unlimited mounting bracket placement along the length. It adjusts to fit many different vehicle beds. Simple, yet elegant mounting brackets included. 1" square tube clamps provided for UTV beds that have exposed tubing.

The proprietary *Cam Lever Latching* feature found on the many optional accessories allows for installation and removal of a given accessory in seconds.

Approximate Installation Time
Experienced Dealer Technician – 30 Minutes
Average Dealer Technician – 45 Minutes
Do-It-Yourself – 90 Minutes

Approximate Product Specifications
Rack Width: Up to 68"
Weight: 55 lbs. (not including accessories)
Capacity: 100 lbs./tool bar (including accessories)



**CAUTION**

**Do not exceed the rated capacity for the Tool Rack or its accessories. Doing so may result in damage to the Tool Rack and will void the warranty**

The contents of this envelope are the property of the owner. Leave with the owner when installation is complete.

All images shown are for illustration purposes only. Actual product may vary due to product enhancement.

## WARNINGS, TIPS, & REQUIRED TOOLS

*Artillian products feature an assembly of parts designed for your vehicle which require adjustment and alignment of components to accommodate vehicle variations and provide proper installation. For accurate installation, proper operation, and years of satisfaction, please read and understand the installation and owner's manual fully prior to installing the product.*

*From all of us at Artillian, we thank you for choosing our product.*

### NOTICE

This product adds additional weight to the base vehicle. All product and accessory weights are listed in the Installation & Owner's Manual. Deduct the product (and accessories) total weight from the vehicle's rated capacity and never exceed the vehicle's rated capacity, including driver and passenger.

### WARNING

This product is intended to increase the functionality of the UTV bed for use in **SLOW SPEED CONDITIONS**. The weight and location of this product and its accessories (when mounted on a UTV bed) will increase the vehicle's center of gravity. This may cause the vehicle to become less stable when driving. Additional caution should be used when driving with this product installed, especially when multiple accessories and/or tools are added.

**TRAVEL SPEEDS MUST BE GREATLY REDUCED TO AVOID ROLLOVER. FAILURE TO COMPLY COULD RESULT IN INJURY OR DEATH.**

This product is not intended for use in trail riding, driving on particularly rough terrain, on slopes, or at high speeds.

Do not attempt to dump the vehicle bed with accessories installed on either the Tool Bar or the Tool Rack. Doing so may result in damage to the Tool Bar, the Tool Rack, the Tool Bar Accessories, or to the vehicle bed or its dumping mechanism.

## GENERAL INFORMATION BEFORE YOU START

- To assist with installation, leave all fasteners loose for later adjustment unless otherwise specified.
- Before installing parts with factory installed rubber, make sure the rubber is fully installed onto parts for proper fit and finish. It is possible that the rubber has shifted during shipment.
- Use caution to avoid damaging factory installed threaded inserts. Begin thread engagement by hand to avoid or correct potential cross-threading.
- Use Loctite (preferably #263) on all bolts installed into threaded inserts.
- Check tightness of all bolts after 150 hours of operation.

## TOOLS REQUIRED:

- Set of Standard and Metric Sockets (3/8" Drive)
- 3/8" Drive Ratchet
- Set of Standard and Metric Open-End Wrenches
- Drill / Driver
- Phillips Head drill bit
- Set of Standard Drill Bits
- Center Punch
- Awl
- C-Clamps

# KIT INSTALLATION

## WARNING

*It is the user's responsibility to ensure that installation of this product does not affect the functionality of the vehicle ROPS, tires, or any other safety feature of the vehicle. Failure to do so may result in injury or death. Due to the many variations between UTV models, the UTV Mounted Tool Bar or Tool Rack or some of its quick removal accessories may interfere with dump bed operation, fender flares, or tires. If necessary, the quick-release Cam Lever Latches on the ROPS Mounted Tool Bar accessories allow a given accessory to be quickly removed and relocated to a non-interfering location.*

*Artillian strives to continuously improve our products. As such, the actual product may vary from the images shown throughout this manual.*

## INSTALLATION

Park the vehicle on a flat, level surface.

- See fig. 1. Install (4) Tool Bar mounting brackets using the installation instructions included with the 1UTVTB kit.
  - Note: It will help to utilize the included tool bar (ref.: 42" long tube) to determine the optimal locations for the mounting brackets on your vehicle bed, but do not fasten the tube to the mounting brackets at this time.
- See fig. 2. With an assistant, install a UTV Tool Rack Vertical Tube (ref.: 32" long tube) onto the inboard side of the mounting bracket, as shown. Ensure that the two threaded inserts on the opposite side of the tube are at the top.
  - Using the tube clamp and hardware provided in the 1UTVTB kit, fasten the vertical tube and the horizontal tool bar to the mounting bracket

**Hardware: 5/16-18 X 1" LG. Flange Head Cap Screws (FHCS)**

- See fig. 3. Repeat step 2 for the second vertical tube.
- See fig. 4. Repeat steps 2 - 3 for the other side of the UTV bed.
- See fig. 5. Install the cross bar mounting brackets to the top inboard side of each vertical tube in the orientations shown.
  - Image 5a is a close-up view of the corner "a" mounting bracket installed on the inboard side of the vertical tube. (Rotated for clarity)

**Hardware: 5/16-18 X 3/4" LG. FHCS**

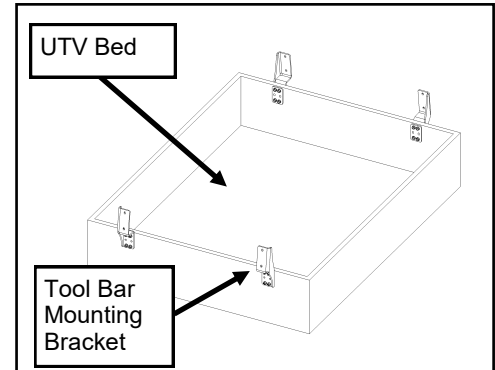

Fig. 1

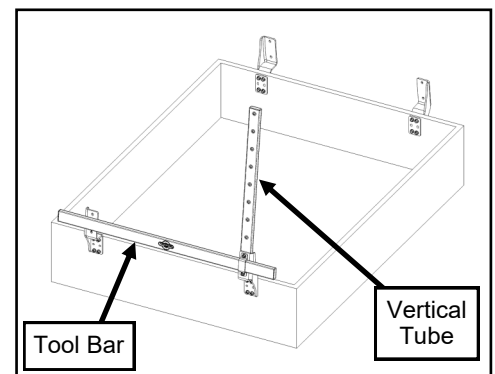

Fig. 2

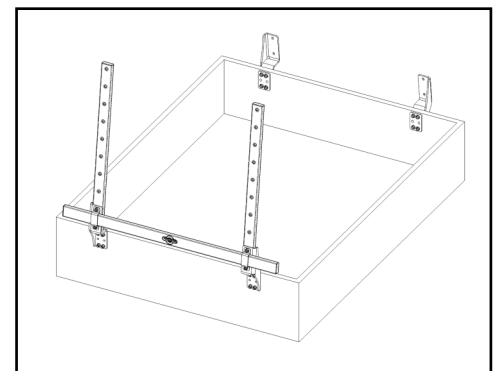

Fig. 3

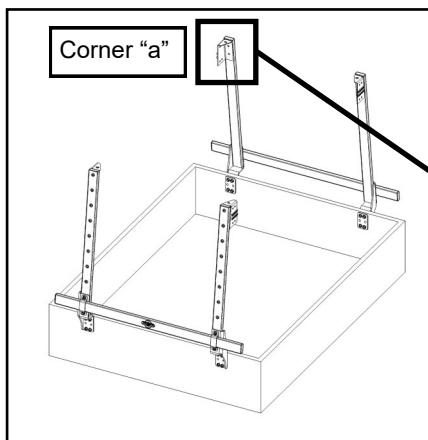

Fig. 5

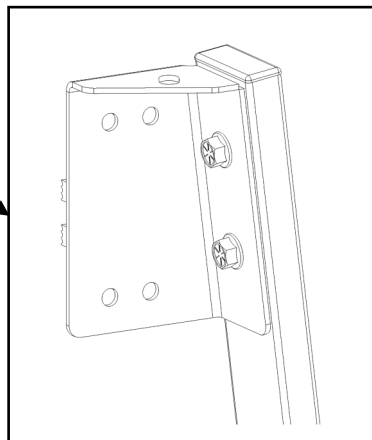

Fig. 5a

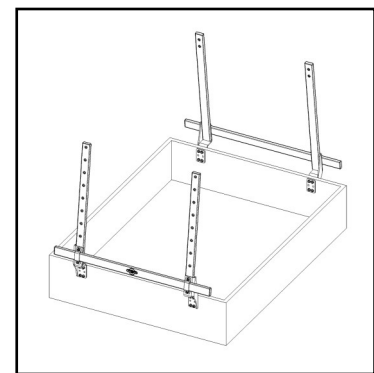

Fig. 4

## KIT INSTALLATION

6. See fig. 6. Using the cross bar tube clamps (4 holes), install a cross bar (ref.: 68" long tube) from left to right onto the cross bar mounting brackets.

**Hardware: 5/16-18 X 3/4" LG FHCS  
5/16-18 Flange Nuts**

7. See fig. 7. Repeat step 6 to install the other cross bar tube onto the rack.

8. See fig. 8. Choose the desired height for a second horizontal tool bar (ref.: 42" long tube) and install, using the tool bar tube clamps (2 holes). One of the middle sets of holes in the vertical tube is recommended.

**Hardware: 5/16-18 X 3/4" LG FHCS**

*Some considerations for second tool bar location are:*

- Height of tool bar accessories intended to be mounted on lower tube. These accessories need to be lifted off the lower tube without interfering with the upper tube.
  - Height of tool bar accessories intended to be mounted on the upper tube. If straddling the vertical tube with an accessory, there must be enough clearance to the overhanging cross bar tube to allow the accessory to be lifted off the tube.
  - Ergonomics of removing accessories from the upper tube, based on operator height.
9. See fig. 9. Repeat step 8 on opposite side of the UTV bed.
10. See fig. 10. Install the *cam lever actuated* Load Retaining Brackets onto the cross bars (ref.: 68" long tube) as shown. These brackets can be loosened quickly by simply lifting the cam lever. Slide them snug against any load being transported on top of the rack (ladders, wood, kayaks, etc.). Lower the cam lever to lock in place.
- A series of slots have been provided in the load retaining brackets and the cross bar mounting brackets. These slots are convenient places for attaching bungee cords or ratchet straps (not included).

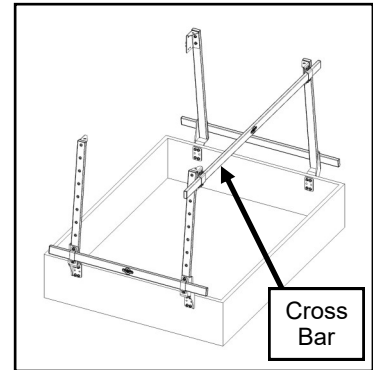

Fig. 6

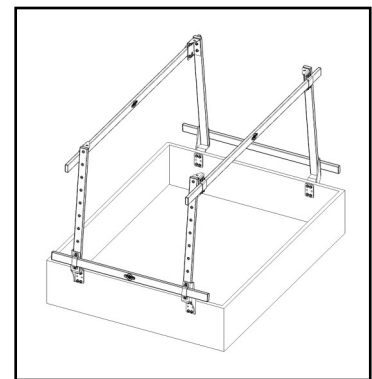

Fig. 7

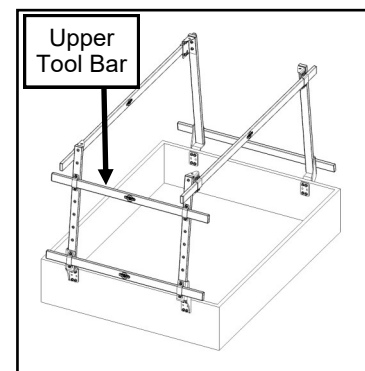

Fig. 8

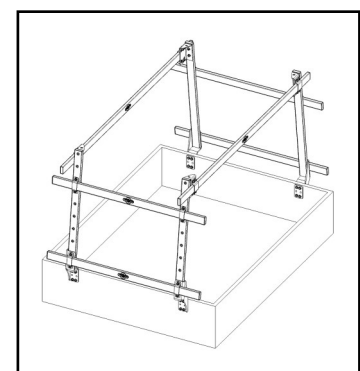

Fig. 9



The use of bungee cords or ratchet straps is required for safely transporting loads on top of the rack. Failure to properly secure the load may result in damage to the tool rack, the load, or even injury to passengers or passerby's. It is the responsibility of the operator to ensure that all loads are properly restrained to the UTV Bed Mounted Tool Rack.

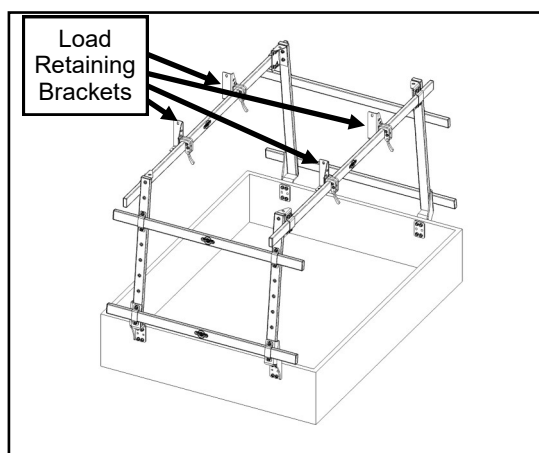

Fig. 10

## FINISHING TOUCHES

1. Make sure the tool bars are tightly fastened in their desired location as the following procedure is meant to securely fasten the tool bar in place and will result in a permanent hole in the tool bar.
2. Using a single sealing washer with each of the self-drilling screws, begin drilling the screws in place at the two locations highlighted in Figures 2.1 and 2.2 (eight in total).

### Hardware Used

#10-32x1/2" Self-Drilling Screw	8
3/8"ODx1/16" Sealing washer	8
Loctite 263	1

### Tools required

Power Drill with Phillips head bit

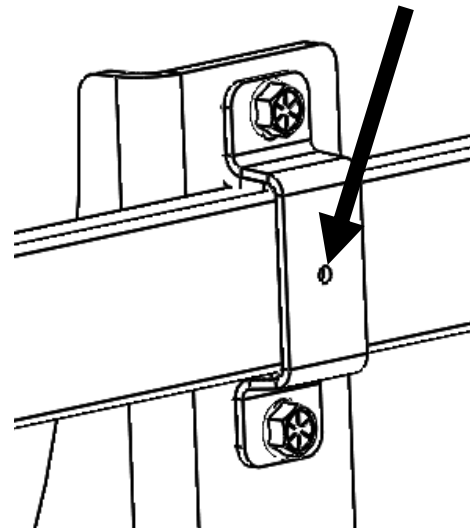

Figure 2.1 (Bracket hole for self-drilling screw)

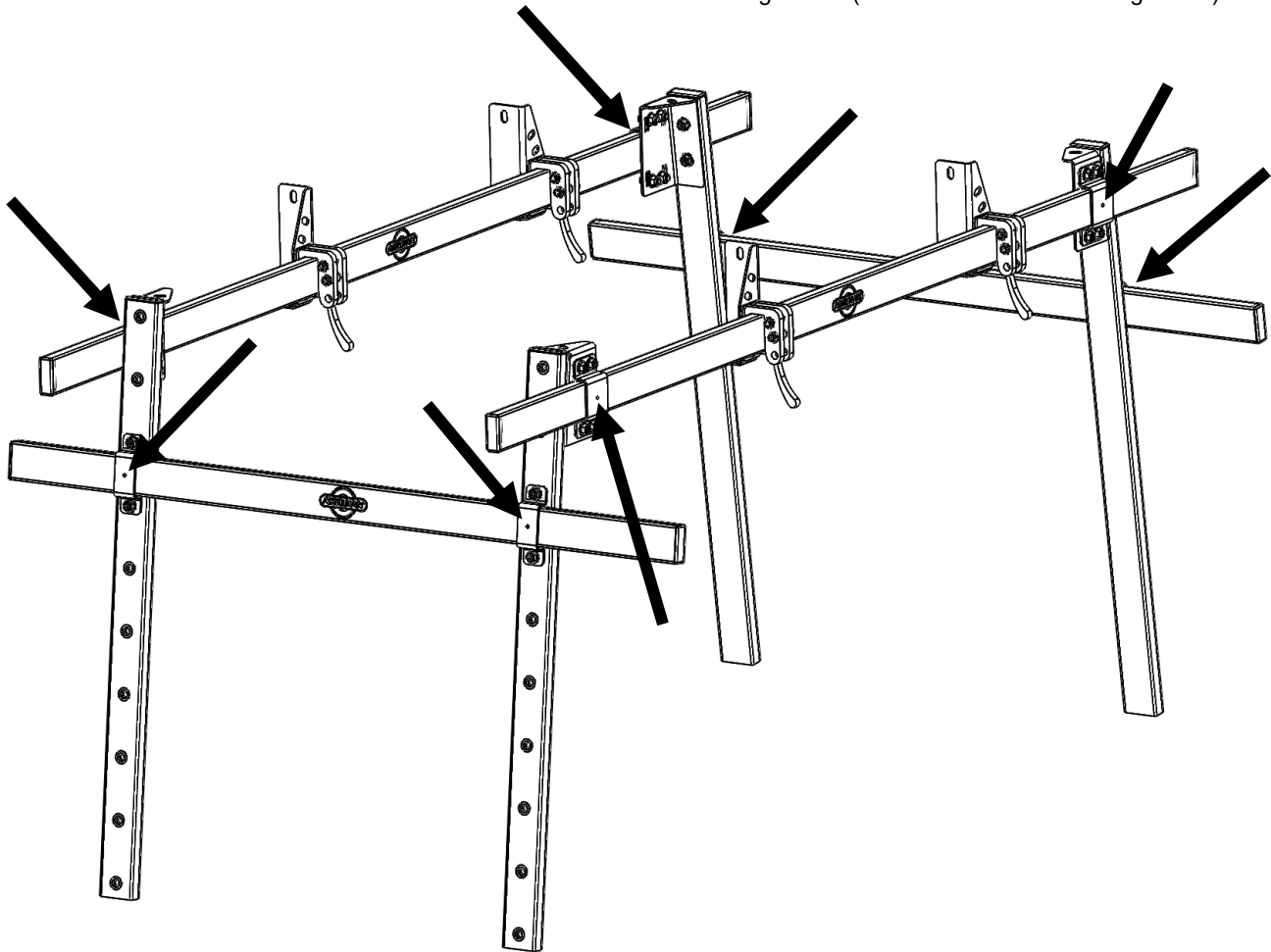

Figure 2.2 (Two points on each bar)

# FEATURES AND OPERATION

## FEATURES

The Artillian UTV Bed Mounted Tool Rack allows for one or more Artillian ROPS Mounted Accessories to be attached to the rack without reducing bed capacity.

The innovation of the design is that any of the compatible accessories can be installed or removed from the Tool Rack in seconds, without the use of tools.

One job may require a toolbox filled with various hand tools. Another might necessitate a tool rack holding assorted long-handle yard tools or maybe a chainsaw mount and fuel can holder.

With the effortless installation and removal of each accessory, you won't waste any time setting up your UTV to carry the specific tool required for the job!

## ATTACHING ACCESSORIES:

1. Figure 1 shows an example of a toolbox installed on a *ROPS Mounted Tool Bar*. Installation onto a *UTV Mounted Tool Rack* is the same.
2. To install an accessory, have both cam levers rotated UP, then place onto the Tool Bar. See fig. 2.
3. To secure the accessory to the mounting bar, rotate both cam levers DOWN until they cam over. See fig. 3.

*NOTE: The accessory can be locked to the Tool Bar by inserting a padlock through the holes in the mounting bracket where shown.*

4. To remove an accessory, rotate both cam levers UP and lift the unit off of the Tool Bar.

## OPERATION

1. Due to the excessive vibrations generated by a UTV, the UTV Bed Mounted Tool Bar and Tool Rack fasteners may loosen up over time. It is recommended that the fasteners are checked and retightened, as required, regularly.

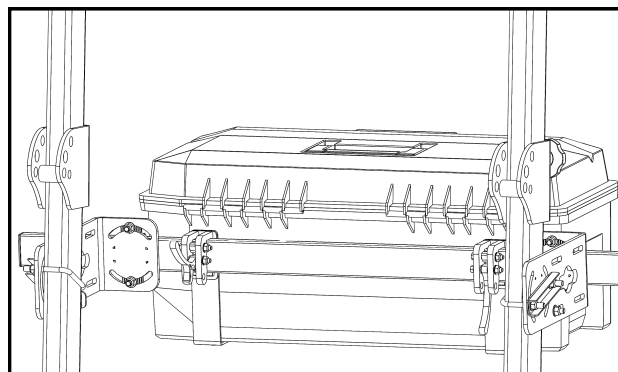

Fig. 1 (example of attaching a tool box)

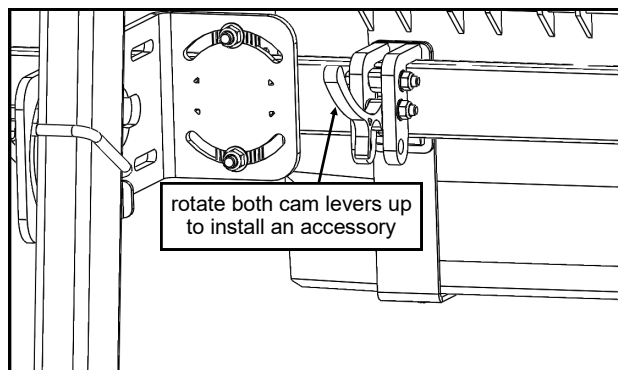

Fig. 2 (cam lever in the open position)

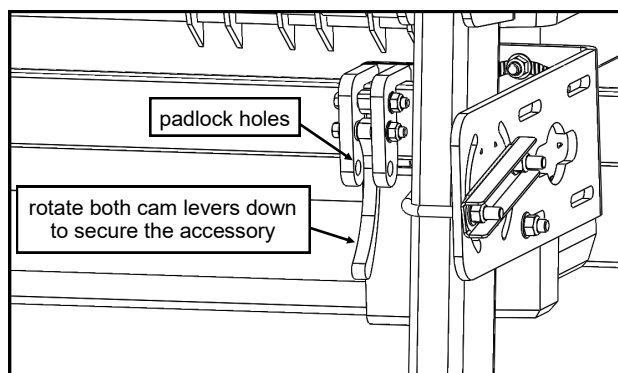
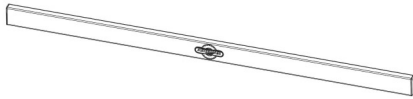

Fig. 3 (cam lever in the closed position)

# SERVICE PARTS:

MOUNTING BAR ASS'Y. (REF.: 42" LG.)  
P/N: 8SV-113-00186 (QTY.: ONE)



CROSS TUBE ASS'Y. (REF.: 68" LG.)  
P/N: 8SV-113-00234 (QTY.: ONE)



VERTICAL TUBE ASS'Y. (REF.: 32" LG.)  
P/N: 8SV-113-00233 (QTY.: ONE)

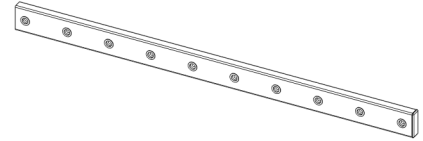

CROSS BAR MOUNT ASS'Y., LEFT  
P/N: 8SV-110-00091-L (QTY.: ONE)

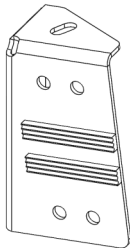

CROSS BAR MOUNT ASS'Y., RIGHT  
P/N: 8SV-110-00091-R (QTY.: ONE)

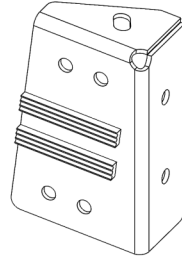

CAM LEVER LATCH  
P/N: 8SV-110-00146 (QTY.: ONE)

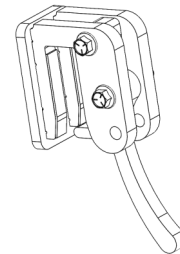

LOAD RETAINING BRKT ASS'Y., LEFT  
P/N: 8SV-110-00087-L (QTY.: ONE)

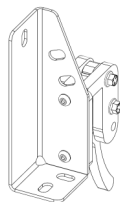

LOAD RETAINING BRKT ASS'Y., RIGHT  
P/N: 8SV-110-00087-R (QTY.: ONE)

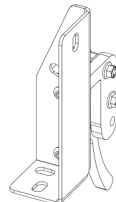

PLASTIC TREE CLIPS  
P/N: 9SV-CP01 (QTY.: 12)

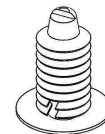

TUBE CLAMP ASS'Y.  
P/N: 8SV-110-00094 (QTY.: ONE)

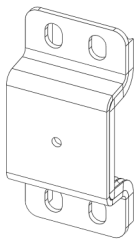

TUBE CLAMP ASS'Y.  
P/N: 8SV-110-00068 (QTY.: ONE)

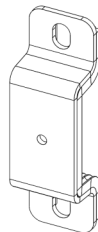

SAFETY WALK ADHESIVE STRIPS  
P/N: 9SV-9PR62-375 (QTY.: 12)

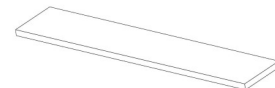

1/2" V-GROOVE WEATHERSEAL  
P/N: 9SV-PR20-10 (QTY.: 10 FEET)



POLY INSERT, 3/4" X 2", RECTANGULAR, BLACK  
P/N: 9SV-9PI04 (QTY.: 2)

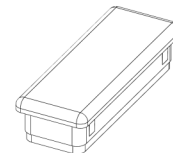

# AVAILABLE ACCESSORIES:

ROPS MOUNTED TOOLBOX, LARGE  
P/N: 1RMTBX5

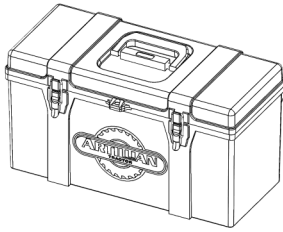

ROPS MOUNTED TOOLBOX, X-LARGE  
P/N: 1RMTBXL

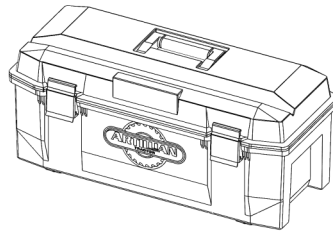

ROPS MOUNTED TOOL RACK  
P/N: 1RMTRK

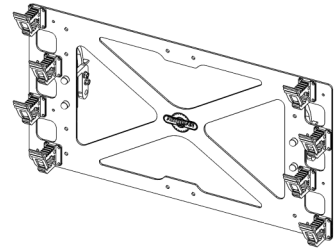

ROPS MOUNTED CHAINSAW MOUNT  
P/N: 1RMCSM  
(chainsaw shown for illustration purposes)

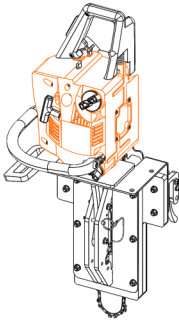

ROPS MOUNTED FUEL CAN HOLDER  
P/N: 1RMFCH

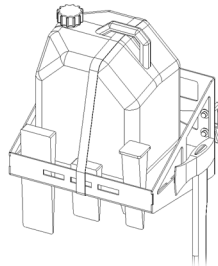

ROPS MOUNTED TOOL BASKET  
P/N: 1RMTBSK

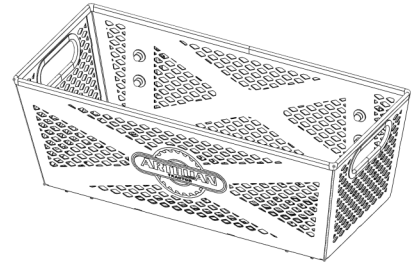

BEVERAGE COOLER HOLDER  
P/N: 1RMBCH  
(cooler shown for illustration purposes)

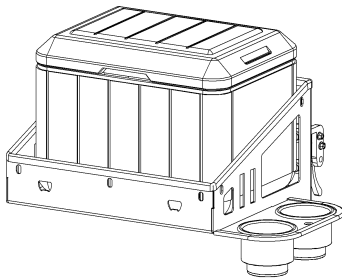

ROPS MOUNTED 5-GALLON BUCKET  
HOLDER - P/N: 1RM5GBH  
(Bucket shown for illustration purposes)

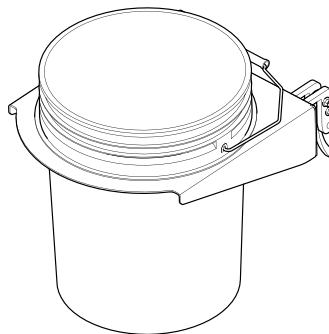

TOOL BAR WALL MOUNT  
P/N: 1RMTBWM

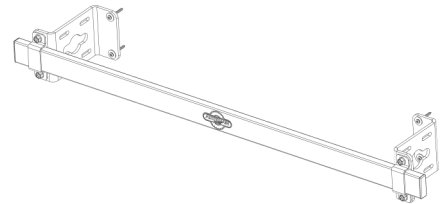

ROPS MOUNTED TOOL BAR  
QUICK RELEASE KIT  
P/N: 1RMTBQR

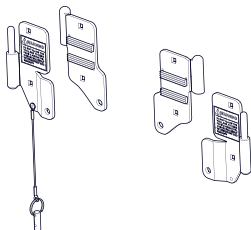

**MORE ACCESSORIES COMING SOON!**



## *Warranty*

**Artillian, LLC** warrants to the original purchaser that this product will be free from defects in material and workmanship for a period of **90 days** from the date possession taken by the original purchaser for use with Artillian hydraulic products and used as intended and under normal service and conditions for personal use. If not purchased for use with Artillian hydraulic products (e.g. Grapple, Plow Adapter, etc.), the warranty period is limited to **30 days**.

Finishes (coatings, labels, & decals) are not inclusive. Artillian, LLC reserves the right to inspect items claimed to be defective in material or workmanship. Artillian LLC's obligation under this warranty is limited to repair or replacement with a nearest similar part.

This Warranty will not apply to any part or product which in Artillian LLC's judgment shall have been misused or damaged by accident, abuse, misapplication, fire, negligence, or lack of normal maintenance or care, or which has been altered or repaired in a way which adversely affects its performance or reliability, or which has been used for a purpose for which the product is not designed.

Artillian, LLC's obligations under this warranty, to the extent allowed by law, is in lieu of all warranties, implied or expressed, including implied warranties of merchantability and fitness for a particular purpose and any liability for incidental and consequential damages with respect to the sale or use of the product warranted. In any event, liability on behalf of Artillian LLC is limited to the original purchase price.

## Tightening of Non-Structural Bolts

For light or medium duty fastening, Curtis recommends using a general industry standard of tightening until snug and then giving an additional one quarter turn of the tool as deemed reasonable for the application (i.e.: at the installer's discretion).

If torque values are required, the examples listed below are intended as a reasonable reference for use in the majority of non-structural fastener applications such as: small diameter fasteners; bolts passing thru tubing, glass, plastic, nylon or rubber washers, threaded inserts, etc.

If more than one application below applies, use the lower torque value.

FASTENER SIZE:	FASTENER TYPE:	WASHER MATERIAL:	APPLICATION:	TORQUE (INCH-POUNDS) (±5)
#10	Machine Screws	-	in Nylon P-Clamps	20
#10	Machine Screws	-	Strobe Light (plastic base)	35
M5	Set Screws	-	Wiper Arm	20
1/4"	Cap Nut	-	Windshield Wiper	20
1/4"	Bolts	-	Tubing (5/8" to 3/4" wide)	132
1/4"	Bolts	Rubber	-	60
1/4"	Bolts	Nylon / Plastic	-	72
1/4"	Bolts	-	Factory Installed Threaded Inserts	132
5/16"	Bolts	-	Tubing (1" or wider)	60
5/16"	Flat Head Bolts	-	Plastic Windshield Hinge	79
5/16"	Bolts	Rubber	-	120
5/16"	Bolts	Nylon / Plastic	-	150
5/16"	Ball Studs	-	-	150
5/16"	Bolts	-	Factory Installed Threaded Inserts	240
3/8"	Bolts	-	Tubing	120
M12	Door Striker Pins	-	-	120